



# ***APA*ds<sup>®</sup>**

---

## **Air conditioning protection & diagnostic system**

## **Installation Manual**

**© 1998 INDEX Sensors & Controls, Inc.  
All Rights Reserved**

The information contained herein is proprietary data, and is not for dissemination or disclosure, in part or in whole, for any purpose other than that for which it is submitted except as authorized in writing by Index Sensors and Controls, Inc. Additions and modifications will be published in future revisions. Index Sensors and Controls, Inc. reserves the right to make changes at any time. This specification conveys no license under any patent, trademark or other right. APA<sup>ds</sup><sup>®</sup> is a registered trademark of Index Sensors and Controls, Inc.  
Patent number 5,761,918.

4046033

# Table of Contents

---

Step 1	Determining the Proper Kit .....	3
Step 2	APAds® Kit Contents .....	4
Step 3	Tools Required for Installation. ....	5
Step 4	Installation of the Low Side Port Adapter .....	6
Step 5	Removal and Installation of Refrigerant Pressure Switches .....	6-9
Step 6	Installation of the APAds Control Module .....	10
Step 7	Installation of the Wire Harness.....	11-13
Step 8	Securing the Wire Harness .....	14
Step 9	Charging of R134a System .....	14
Step 10	Identifying the APAds System .....	14
Step 11	Testing APAds .....	15
	Charging A/C System .....	16
	Troubleshooting .....	17-19
	Wiring Diagram .....	20
	Spare Parts Chart .....	21
	Warranty .....	22

# Step 1 Determining the Proper Kit

Before installing the APAdS kit, it is important to verify that the proper kit has been chosen for the vehicle. The APAdS kit required will depend upon the following variables:

1. **Type of refrigerant.** Determine whether the air conditioning utilizes R12 or R134a refrigerant. If uncertain, check the vehicle’s maintenance manual or the label on the air conditioning compressor.
2. **Number of low side refrigerant ports available.** If the air conditioning system utilizes R134a refrigerant, note the number of low side refrigerant ports available. If a low side pressure switch port is not available, an adapter will be necessary. (See step four, page six for adapter installation procedures.)
3. **Determine the fitting of the high side pressure switch port.** Is the port a standard 1/4 inch flare or a metric M10 fitting? \* Some OEMs use 1/4” flare fittings on R134a driers.
4. **Vehicle must be a thermostatic expansion valve (TXV) system.**

Once the above information has been collected, utilize the chart in figure 1.1 to verify the correct part number.

**Figure 1.1**

	R12	R12	R134a	R134a	R134a
<b>Differences</b>	Trinary switch	No trinary switch	Low side port M12. High side port M10.	No low side port. High side port M10.	No low side port. High side port 1/4 NPT.
<b>Vehicles</b>	All makes with thermostat expansion valve (TVX) system.		Navistar Volvo	Kenworth Freightliner (some models) Mack Trucks Western Star	Freightliner (some models)
<b>Kit Part Numbers</b>	8041125	8041124	8041121	8041122	8041123

# Step 2

# APAds® Kit Contents

Figure 2.1

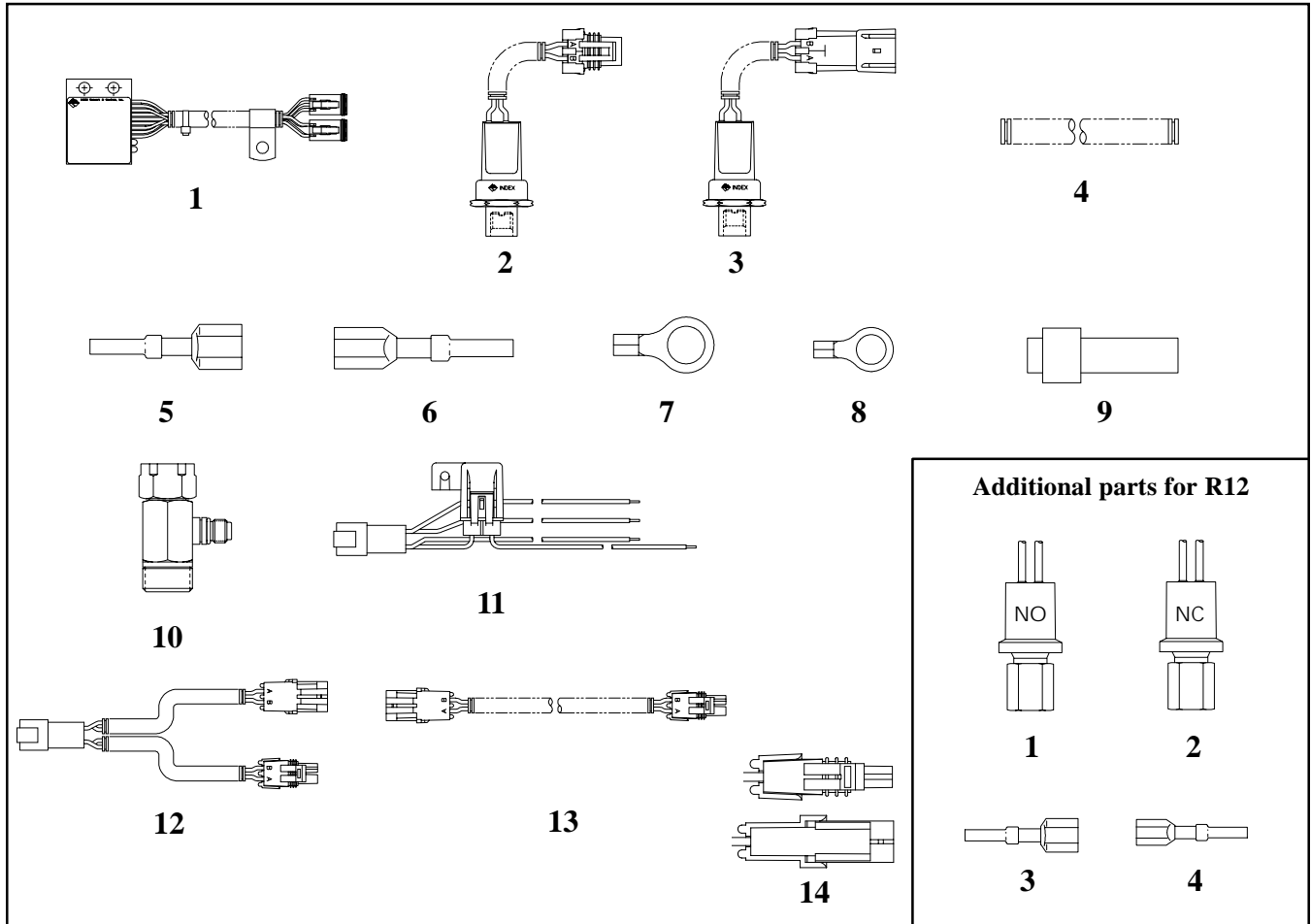

## Standard APAds Kit

Item	Description	Quantity	Item	Description	Quantity
1	APAds control module	1	8	1/4 inch ring terminal	1
2	High side refrigerant pressure switch	1	9	Tie straps	12
3	Low side refrigerant pressure switch	1	10	Low side port adapter	2
4	Conduit	1	11	(only on kit nos. 8041122 and 8041123)	
5	Male spade connector	2	11	Six-pin wire harness	1
6	Female spade connector	2	12	Pressure switch wire harness	1
7	3/8 inch ring terminal	1	13	Pressure switch wire harness extensions	2
			14	Weatherpack connectors	2

## Additional parts for R12 systems with trinary pressure switch:

Item	Description	Quantity	Item	Description	Quantity
1	Fan pressure switch (NO)	1	3	Male spade connector	2
2	Fan pressure switch (NC)	1	4	Female spade connector	2

If any parts are missing, contact Index at (800) 726-1737.

# Tools Required for Installation Step 3

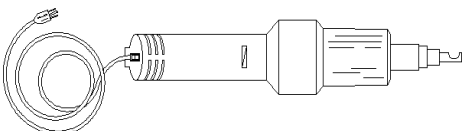
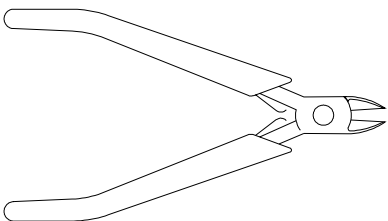
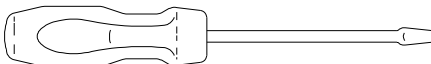
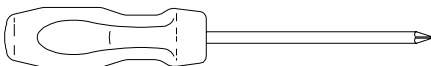
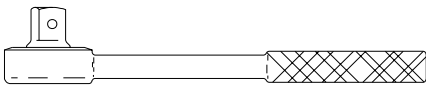
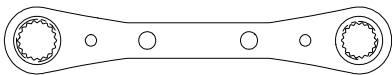
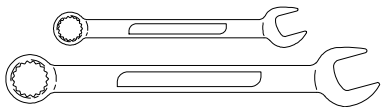
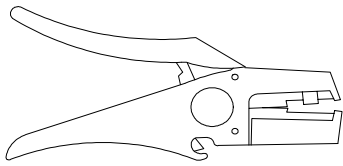
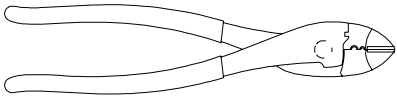

The following is a list of tools Index requires to ensure quality installation.

- Crimping tool - used on the spade connectors.
- Wire stripper
- Wrenches
  - 9/16 inch
  - 1 3/16 inch
- A/C wrench
- 9/16 inch socket
- 3/8 inch drive ratchet
- Screwdrivers
  - Cross tip
  - Flat head
- Wire snips
- Torque wrench
- Heat gun
- Voltmeter
- Charging station

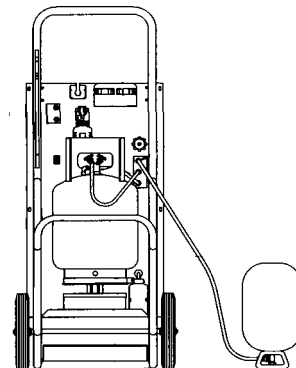
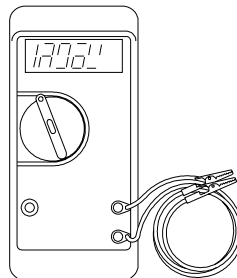

# Installation of the Low Side Port Adapter

## Step 4

If a low side pressure port exists, continue to step five.

For vehicles that do not have a low side pressure port, do the following:

1. Using a recycling machine, remove the refrigerant from the system.
2. Locate the suction side hose coming off the compressor; disconnect low side hose from compressor.
3. Install adapter between compressor and suction side hose (if adapter will not work in the application, call Index technical department (800)726-1737).

*Note:* Make sure all O-rings are properly lubricated with correct refrigerant oil.

*Note:* Check new routing of the suction side hose and ensure that there is no rubbing or chafing.

4. Install low pressure switch provided in the kit on adapter.
5. Evacuate the system for at least thirty minutes. While evacuating go to step 5.

# Removal and Installation of Refrigerant Pressure Switches

## Step 5

These switches may be found in the following locations:

**R12 A/C systems:** The ports are positioned in three possible locations: on the air conditioning compressor, on the receiver dryer, or on the expansion valve. (See figure 5.4, page nine.)

**R134a A/C systems:** The port is located either on the receiver dryer or in the high side line between the compressor and the receiver dryer. (See figure 5.5, page nine.)

**If your vehicle has a Trinary™ pressure switch:** (This section covers most vehicles that have R-12 refrigerant and most Western Star applications).

1. Turn A/C controls in dash to the “On” position.
2. Turn vehicle ignition switch to the “On” position. A/C clutch should be engaged at this time.
3. Locate the Trinary™ switch on your vehicle (in most applications the Trinary™ is located on the receiver drier or the expansion valve. See figure 5.4 or 5.5, page nine.)
4. Disconnect the compressor and the T-stat wire from the Trinary™ switch. The A/C clutch should be disengaged at this time. Connect the compressor and T-stat wires together using the heat shrinkable connectors provided in the kit. (See figure 5.1 and 5.2, page seven.)
5. Disconnect the 12 volt power and engine fan wires from the Trinary™ switch.
6. Remove the Trinary™ switch (no longer needed).
7. Two engine fan pressure switches have been provided in the kit. A normally open (NO) and a normally closed (NC).

Binary™ and Trinary™ are registered trademarks of the Red Dot Corporation.

12335 134<sup>th</sup> Ct NE | Redmond, WA 98052-2433 | Phone: 800/726-1737 | www.indexsensors.com  
Sales/Mktg. Fax: 425/821-4112 | Purchasing Fax: 425/821-9501 | Engineering Fax: 425/821-8057

# Removal and Installation of

## Step 5 Refrigerant Pressure Switches (Cont.)

8. Before installing the engine fan pressure switch, it will be necessary to determine whether the fan system is NO or NC. The pressure switch that you select must match your vehicle.
9. To determine which fan system is used, turn off the ignition switch and attempt to rotate the engine fan. If the fan spins freely, the system is NO. If the fan is locked, the system is NC.
10. Choose the engine fan pressure switch that matches your vehicle. NO for normally open fan systems, NC for normally closed fan systems.
11. Install the correct engine fan pressure switch in the former Trinary™ switch port. Electrically connect the remaining two wires from the former Trinary™ switch to the engine fan pressure switch using the heat shrinkable connectors provided in the kit. (See Figure 5.3.)
12. See figure 5.4 and 5.5 for installation locations of the low and high pressure switches provided in the kit.

Figure 5.1

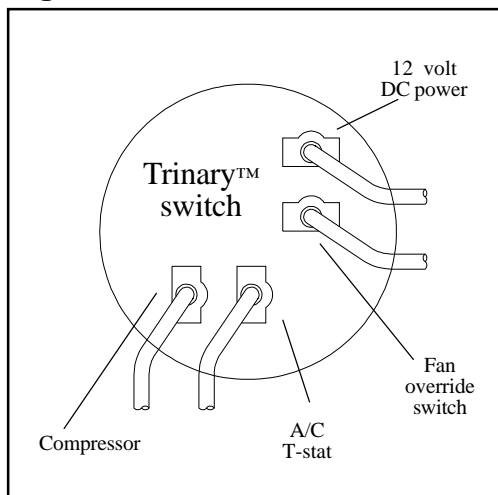

Figure 5.2

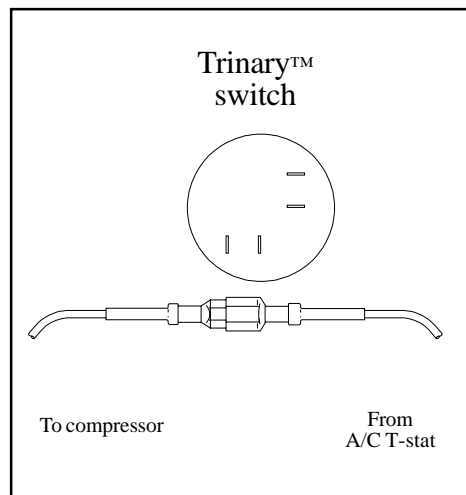
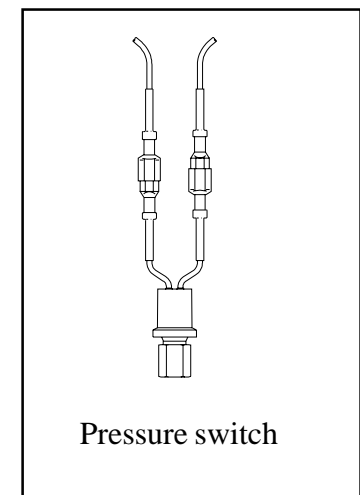

Figure 5.3



**If vehicle has a Binary™ pressure and engine fan pressure switch:** (This section covers most **Freightliner, Kenworth, and Mack** applications).

1. Turn A/C controls in dash to the “On” position.
2. Turn vehicle ignition switch to the “On” position. A/C clutch should be engaged at this time.
3. Determine which switch is the Binary™ switch and which is the engine fan pressure switch. The engine fan switch will be left on the vehicle.
4. If your high side pressure switch is located on the receiver drier, you will need to determine the type of refrigerant port on the vehicle. There are two configurations: standard 1/4” female flare and a metric M10 female flare.
5. Disconnect the compressor and the T-stat wire from the Binary™ pressure switch.
6. Connect the compressor and T-stat wires together using the heat shrinkable connectors provided in the kit. The A/C clutch should engage.
7. Band and secure the two wires so they do not hang freely.
8. Remove Binary™ switch and install high side pressure switch provided in the kit.

# Removal and Installation of

## Step 5 Refrigerant Pressure Switches (Cont.)

---

**If vehicle has a high side compressor cutout switch, a low side compressor cutout switch, and an engine fan pressure switch:** (This section covers most Navistar applications).

1. The high side and low side compressor cutout switch will be located in one of two places: under the passenger seat or behind the passenger side kick panel.
2. With the switches installed on the vehicle, and with a full refrigerant charge, disconnect the wiring going to the pressure switches.
3. Determine if the high and low pressure cutout switches are normally open (NO) or normally closed (NC) by checking resistance values across the switch terminals with an ohm meter. A NC switch will read less than 5 ohms when checking with an ohm meter. A NO switch will read an open loop or high resistance (>100k ohms) with an ohm meter.
4. If the switch is NC, bypass the switch by cutting the plug from the harness and splicing the wires together with the heat shrinkable connectors provided in the kit. NO switches do not need to be rewired and the connection can remain open.
5. Band and secure the loose wires so they do not hang freely.
6. Remove switches and install the high and low side pressure switches provided in the kit.
7. The engine fan switch is located on the A/C compressor, nothing will be done with this switch.

**NOTE:** Pressure switches cannot be installed on the wrong refrigerant port. The high side switch has a M-10 pressure port housing, the low side switch has a M-12 pressure port housing.

**If vehicle has a high side compressor cutout switch, a high side low pressure cutout switch, a low side compressor cutout switch, and an engine fan pressure switch:** (This section covers most Volvo applications).

1. Location of pressure switches:
  - The high side compressor cutout switch:** is located near the inlet of the condenser. This switch will have to be removed and the port will have to be capped off.
  - The high side low pressure compressor cutout switch:** is located on the passenger side wheel well.
  - The low side compressor cutout switch:** is located in the passenger side wheel well.
  - The engine fan switch:** is located in the passenger side wheel well. Nothing will be done with this switch.
2. With the switches installed on the vehicle, and with a full refrigerant charge, disconnect the wiring going to the pressure switches.
3. Determine if the high and low pressure cutout switches are normally open (NO) or normally closed (NC) by checking resistance values across the switch terminals with an ohm meter. A NC switch will read less than 5 ohms when checking with an ohm meter. A NO switch will read an open loop or high resistance (>100k ohms) with an ohm meter.
4. If the switch is NC, bypass the switch by cutting the plug from the harness and splicing the wires together with the heat shrinkable connectors provided in the kit.
5. NO switches do not need to be rewired and the connection can remain open.
6. Band and secure the loose wires so they do not hang freely.
7. Remove switches and install the high and low side pressure switches provided in the kit.



# Removal and Installation of Refrigerant Pressure Switches (Cont.) Step 5

Figure 5.4 Pressure Switch Locations for R12

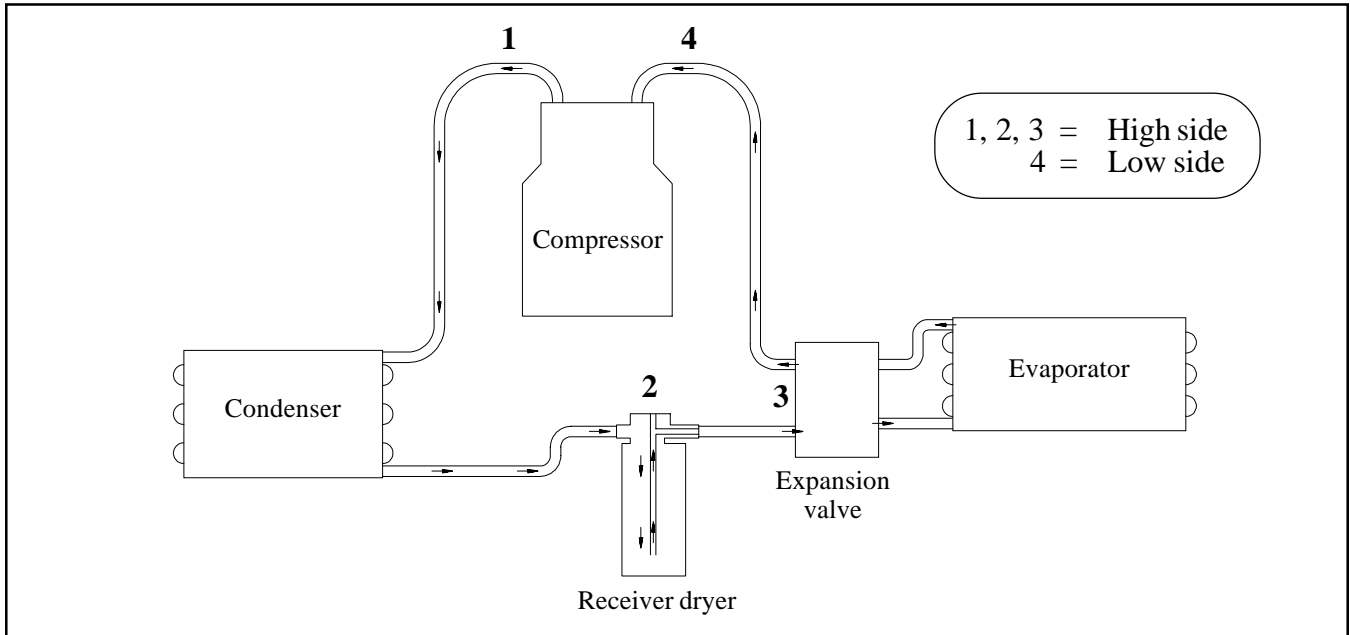
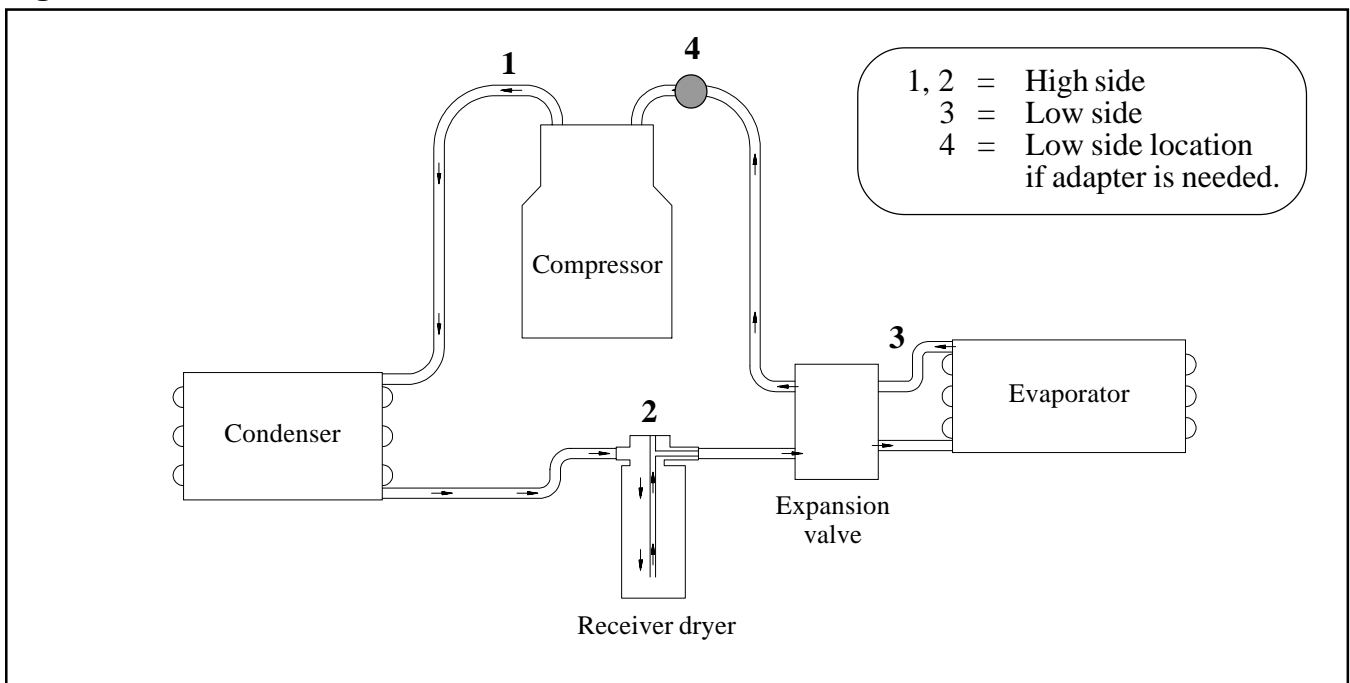

Figure 5.5 Pressure Switch Locations for R134a



# Installation of the APAds® Control Module

## Step 6

The APAds control module must be installed *in a location where the diagnostic lights are clearly visible*. (See figure 6.1.)

1. Determine a mounting location for the APAds control module.

The following are recommended mounting positions:

- On the vehicle bulkhead wall located on the passenger side of the engine.
- On or near the air conditioning compressor bracket.
- On the upper radiator bracket located on the passenger side of the engine.

2. Install the APAds control module with a 3/8 inch bolt with lock nut and tighten to 25 ft. lbs. Although the APAds control module has two mounting holes, it is not necessary to utilize both holes when installing the unit.
3. The mounting clamp on the wires can be mounted on the back side of the APAds control module. In some cases it may not be necessary to use a mounting clamp, but the wires must be strapped down (see figure 7.1 to identify the mounting clamp).

**Figure 6.1**

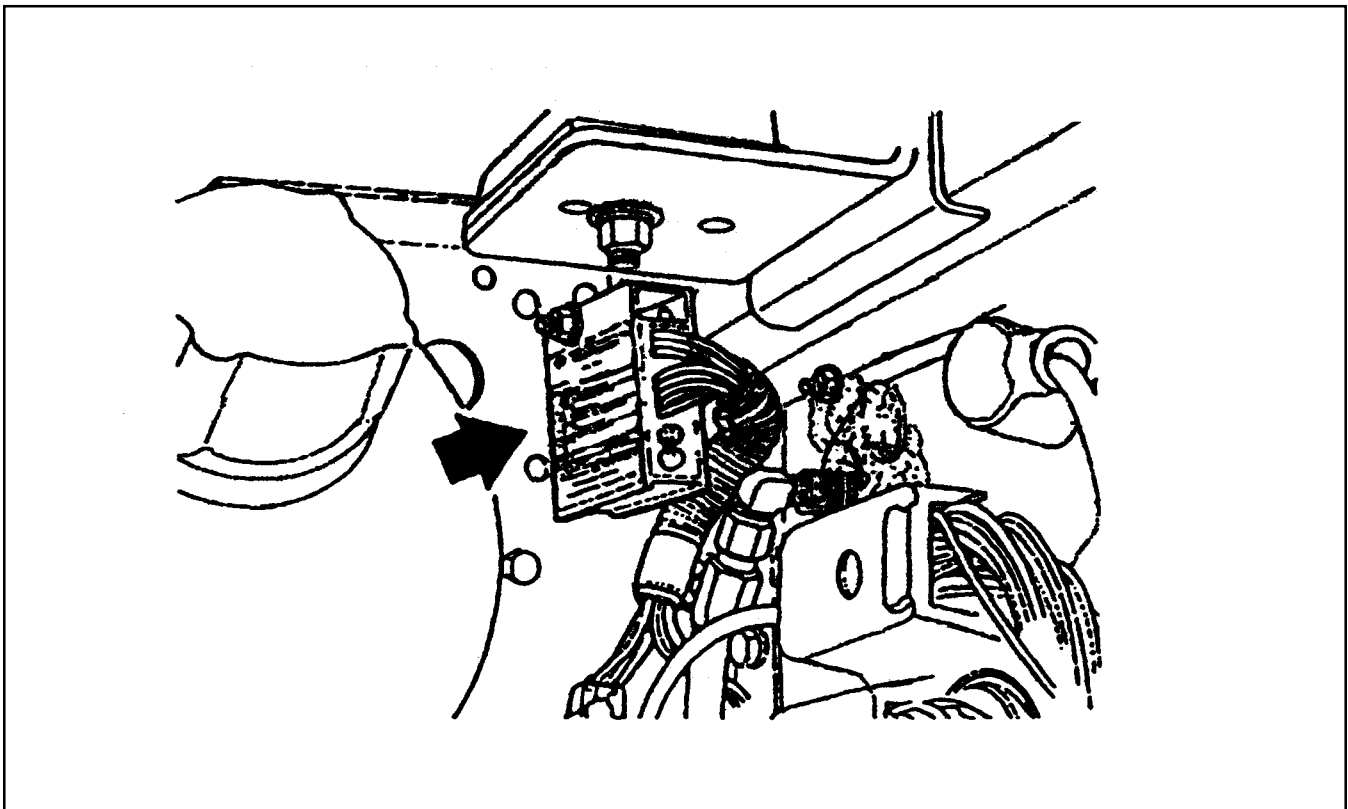

## Step 7 Installation of the Wire Harness

---

1. Make certain the ignition is in the “Off” position.
2. Locate and connect the four pin connector on the pressure switch wire harness to the four pin connector on the control module. If harness is not long enough, use the extension harness which is provided in the kit. **Do not cut the wires to make extensions.**
3. Connect the appropriate pressure switch wire harness to the A/C high pressure switch. Connectors are arranged so that the connection can only be made the correct way.
4. Connect the remaining pressure switch wire harness to the A/C low pressure switch.

**IMPORTANT! Do not strain the wires in the harness. Use the extensions included in this kit to provide adequate strain relief.**

5. Locate the six pin connector on the harness and connect it to the APAds control module.

**NOTE:** This harness has bare leads on one end. It will be necessary to cut these wires based on the required length needed for installation.

**NOTE:** The spade connectors which are supplied in the kit have an integral, heat shrinkable seal. After crimping the quick disconnect connectors, use a heat gun to shrink the seal.

6. The red wire is the power wire. It should be connected to a 12 volt keyed ignition source at the power distribution box. When connecting to power, the source must be able to handle a 7.5 amp continuous draw. Index recommends installing a dedicated circuit breaker for the APAds control module. If needed, a ring terminal and heat shrink have been provided for this connection.
7. The black wire is the ground wire. It is essential to achieve a good ground. Index recommends going to the power distribution box for your ground connection or using the ground post on the alternator. A ring terminal and heat shrink have been provided for this connection.
8. Locate the air conditioning compressor and its power source wire.

**IMPORTANT! If you have a two wire connector on your compressor, you will need to contact Index for technical support at (800) 726-1737.**

9. Disconnect the power source wire from the compressor. This connector should be located approximately six to ten inches from the compressor. See figure 7.1, page 12.

# Installation of the Wire Harness (Cont.) Step 7

Figure 7.1

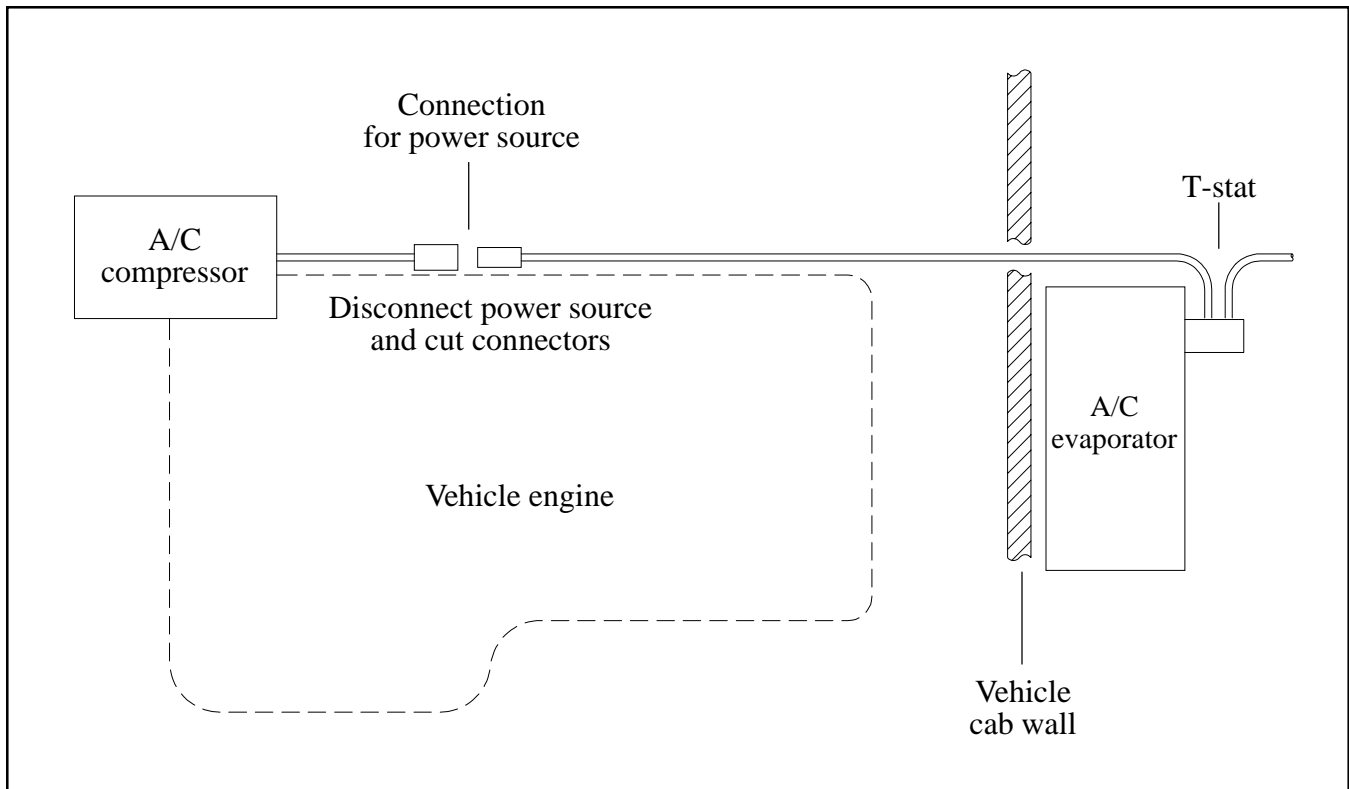

10. Connect the blue wire from the APADs control module to the wire connected to the air conditioning compressor clutch. See figure 7.2, page 13.

If the vehicle manufacturer's recommended connectors are not available, remove the existing connector by cutting the wire and install the spade connectors supplied in the APADs kit.

11. Connect the green wire from the APADs control module to the remaining wire that was disconnected from the compressor earlier in this step, utilizing the vehicle manufacturer's recommended connectors if possible. See figure 7.2.

If the vehicle manufacturer's recommended connectors are not available, remove the existing connector by cutting the wire and install the spade connectors supplied in the APADs kit.

12. At this point, all wires should be connected. See figure 7.3, page 13.

# Step 7 Installation of the Wire Harness (Cont.)

Figure 7.2

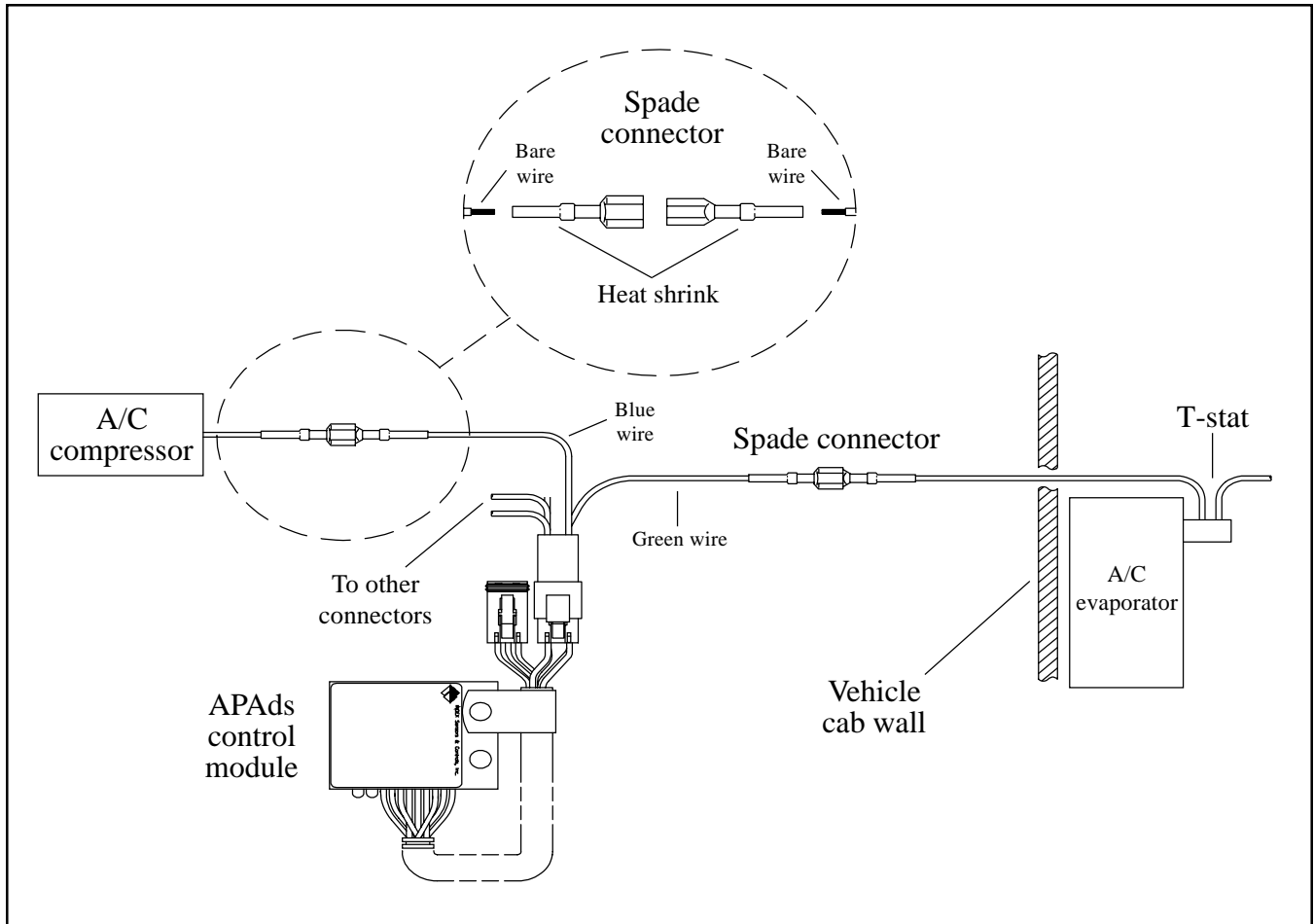
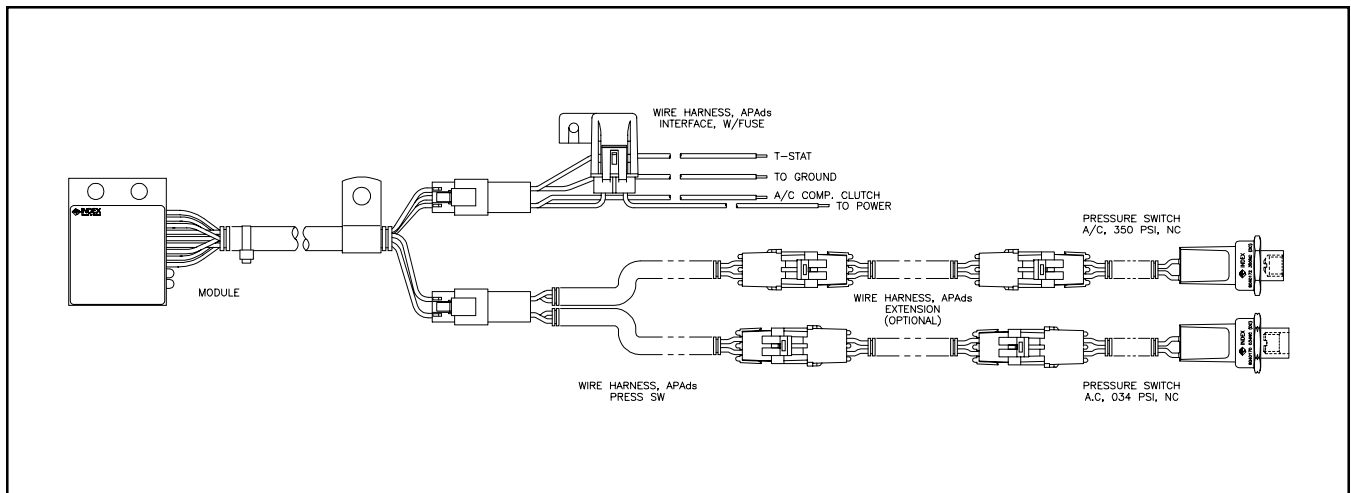

Figure 7.3



# Securing the Wire Harness

## Step 8

---

Using the tie wraps and conduit supplied in the APAds kit, protect the wires with conduit as necessary. Fasten the six pin wire harness to the vehicle. Fasten wraps about every eight to 12 inches. Be certain not to put too much stress on the wires when installing the tie wraps. The wire should be fastened tightly but not so tight as to put stress on the harness. Leave adequate strain relief for each component, including connectors.

# Charging of R134a System

## Step 9

---

If a low side port adapter was installed on the system, charge system at this point.

*Note:* Refer to owner's manual for proper amount of refrigerant.

Both high and low side quick disconnect ports should be available. If both ports are not available, call Index for technical assistance at (800) 726-1737.

# Identifying the APAds<sup>®</sup> System

## Step 10

---

1. Locate the APAds system sticker in the APAds kit.
2. Mount this sticker on or near the compressor. This will allow other technicians to identify the system if there is an A/C problem.

**Important! Once installed, APAds may immediately diagnose existing A/C system faults. For this reason, testing must be completed to ensure the system has been installed correctly and is functioning properly. A troubleshooting guide is included in this manual (pages 17-19) to assist in diagnosing A/C system faults.**

To ensure that APAds is working properly, please complete the following tests. If the module displays blink codes or the module is not functioning, consult the Troubleshooting section of this manual.

## Test #1

1. Turn the vehicle ignition to the “On” position and be certain that the A/C controls are in the “Off” position. The green light on the APAds control module should be illuminated.
2. After 15 seconds, the A/C compressor should engage.
3. After another 15 seconds, the A/C compressor clutch should disengage.
4. Turn the A/C switch on; listen for the clutch to engage.
5. Turn the A/C switch off; listen for the clutch to disengage.

## Test #2

1. With ignition off, disconnect the low side pressure switch.
2. Turn on ignition. The red light on the module will blink four times within 15 seconds.
3. Reconnect the low side pressure switch.
4. Clear the error code by cycling ignition four times (one second on/one second off) and the green light will reappear.

If the APAds control module has passed all of these tests, it has been successfully installed.

# Charging A/C System

## Charging an R12 A/C system.

If there are not any high and low charge ports available, you will need to remove the pressure switches.

1. Turn off vehicle ignition before proceeding.
2. Remove the high and low side pressure switches from the ports, and install service gauges.
3. Disconnect six pin connector from the control module. Jump pin 1 and pin 2 on the wire harness. See figure 12.1. This sends 12 volts to the A/C compressor allowing you to charge the system without the pressure switches being installed.
4. Proceed with recharging the A/C system per recommended industry standards.
5. After charging has been completed, reinstall pressure switches and six pin harness to control module.  
*Note:* Install and plug in pressure switches before plugging in six pin connector. Failure to do this will cause the module to detect an open wire fault, and display a four-blink code.

## Charging an R134a A/C system.

Both high and low side quick disconnect ports should be available. If both ports are not available, call Index for technical assistance at (800) 726-1737.

**Figure 12.1**

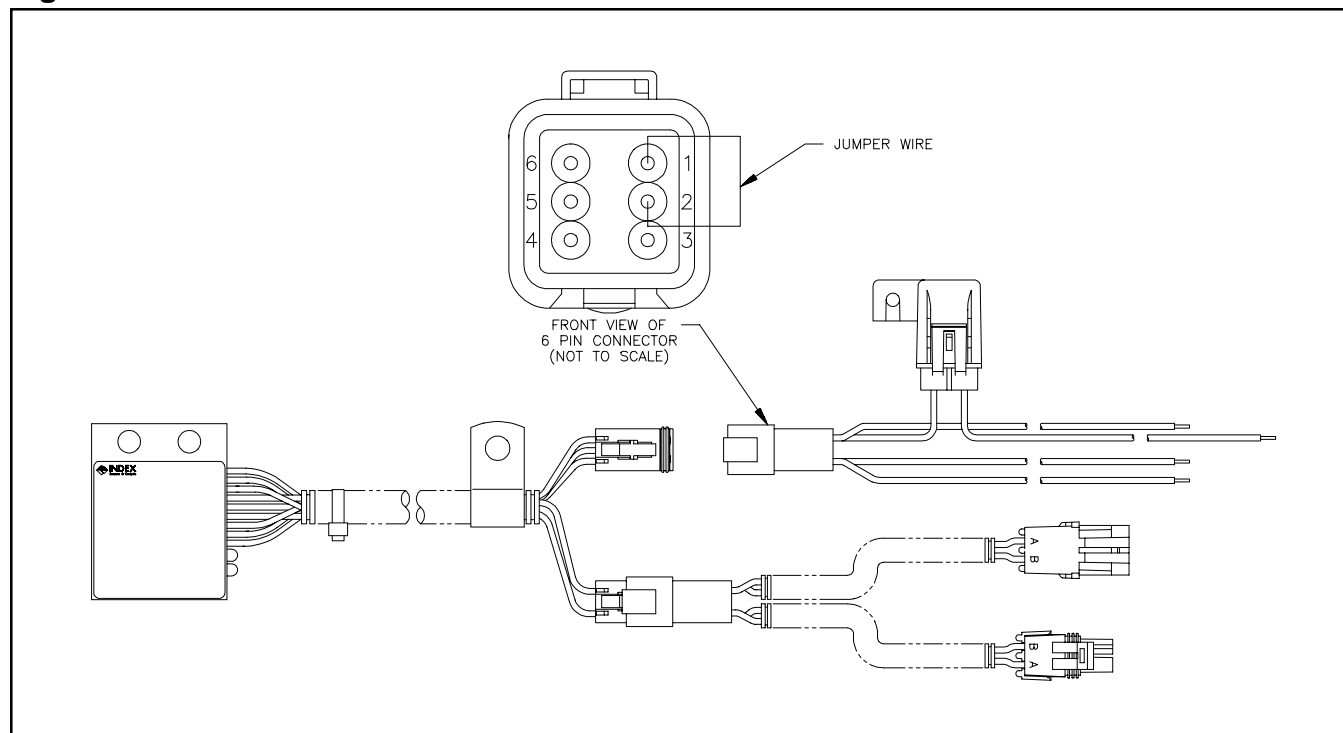



# Troubleshooting

## BLINK CODES

Slow Green:	Unit is functioning properly
Fast Green:	Low System voltage
One Red Blink:	Loss of refrigerant
Two Red Blinks:	Fan failure or external condenser blockage
Three Red Blinks:	Voltage drop out, open or shorted wire to compressor clutch
Four Red Blinks:	Open wire in pressure switch circuit

Condition	Definition	Possible Cause	Action
Slow flashing green light.	Two seconds on, 1/4 second off.	Unit is functioning properly.	No action needed.
Rapid flashing green light.	Low system voltage, indicates low supply voltage condition. Voltage has dropped below 11.0 volts.	Possibly caused by a defective alternator, discharged batteries, poor ground or an excessive electrical load.	Check voltage at the control harness by probing pins 4 (ground) and 2 (power). If voltage is less than 11.0 volts start checking for voltage drops or a poor ground.
Ignition on, LEDs not flashing on control module or no lights on module.	Control module not receiving battery voltage.	Fuse or circuit breaker blown.  Broken power or ground wire to control module.  Defective control module.	Repair fuse or reset circuit breaker.  Repair wiring.  Replace control module.
Red light flashing one blink in sequence.	Low pressure fault. This is detected by monitoring the ambient temperature and switching activity of the low pressure switch.	A partial or total loss of refrigerant.  A defective low pressure switch.  Bad Schrader valve stem.	Install service gauges and check system for leaks.  Disconnect the low side pressure switch connector and measure the resistance value of the switch. If the resistance shows 2.49k ohms, switch is operating properly. If resistance shows less than 5 ohms, replace the switch.  Verify with the gauge set. Replace if necessary.  <i>NOTE: This check must be done with the switch installed on the vehicle and the ignition in the off position and proper charge.</i>

Condition	Definition	Possible Cause	Action
Red light flashing two blinks in sequence.	High pressure fault. The system is exhibiting abnormal high pressure activity.	Overcharge of refrigerant system.  Fan drive failure.  Blocked air flow through the condenser.	Reclaim refrigerant and charge.  Inspect proper operation of solenoid valve/relay and/or related components.  Remove restriction from condenser.
Red light flashing three in sequence.	Open wire to A/C clutch. Detected by inadequate current through the compressor clutch. If no current is sensed when the A/C drive is turned on, an open connection to the clutch coil is indicated.  Shorted wire or shorted A/C clutch. Detected by excessive current through the compressor clutch.  Fluctuating battery voltage.	A break in the wiring between the control module and the A/C compressor clutch or a break in the clutch coil.  This is indicative of either a shorted clutch coil or shorted wiring to the clutch.  Fluctuation of greater than one volt caused by a defective voltage regulator.	With the use of an ohm meter, check the resistance of the clutch coil. If the reading is less than 2.8 ohms, replace the clutch.  On the truck harness side of the 6 pin connector verify the resistance between pins one and four is either greater than 5 ohms for an open clutch condition or less than 2 ohms for a shorted clutch condition.  Next, check for a bad clutch or bad clutch ground. If clutch resistance is greater than 5 ohms to ground, verify the ground connection before replacing the clutch. If clutch resistance is less than 2 ohms replace the clutch. If the clutch is OK locate the opened frayed or shorted wiring and repair.  Replace alternator / regulator unit.
Red light flashing four blinks in sequence.	Opening in wiring harness to high or low pressure switches.	Unseated connector.	Check both the module and the pressure switch connectors for loose pins.

# Troubleshooting (Cont.)

Condition	Definition	Possible Cause	Action
		<p>Break between wiring harness and pressure switch.</p> <p>Moisture intrusion into the connectors or switch.</p> <p>The use of a non-Index pressure switch.</p>	<p>Check connector seals for integrity.</p> <p>Check pressure switch circuits for continuity.</p> <p>In a properly charged system: Disconnect the high pressure switch and verify the resistance between the switch's two contacts is between 2.4K and 2.6K ohms.</p> <p>Install the correct pressure switch.</p>
<p>A/C clutch not engaging during the first 15 seconds after ignition is turned on.</p>		<p>Unit is functioning properly. Regardless of A/C system state at start up, the A/C clutch is disengaged for the first 15 seconds.</p>	
<p>At ignition turn on with A/C controls set to the on position, compressor is off for 15 seconds, on for 15 seconds, then remains off indefinitely.</p>	<p>No voltage on the A/C ON / Evaporator thermostat circuit. Six way truck harness connector, pin 5.</p>	<p>Defective A/C ON / Evaporator thermostat circuit.</p>	<p>With the ignition on and the A/C switch on and the evaporator core temperature above 50 degrees there should be system voltage on the truck harness connector at the A/C ON / Evaporator thermostat pin.</p> <p>Check for a bad A/C On switch.</p> <p>Check for break in wiring between A/C On switch and the evaporator thermostat.</p> <p>Check for bad evaporator thermostat.</p> <p>Check for break in wiring between the evaporator thermostat and the APADs module.</p> <p>Check for bad A/C relay.</p>

# Troubleshooting (Cont.)

Condition	Definition	Possible Cause	Action
At start up, after 15 seconds, compressor clutch doesn't engage but engine fan engages.	Control module sensing an opening in the high pressure switch circuit.	High side pressure switch failure.	In a normally pressurized system: Disconnect the high pressure switch. A good switch should measure less than 5 ohms. If not, replace the switch.
Slow flashing green, compressor on for a short period of time, off for 15 seconds in a repetitive sequence.	Indicates that the system is exhibiting abnormal high or low pressure activity.	Blockage in the high side of the system or in the condensor.  Partial loss of refrigerant.	Repair restriction.  Check system for loss of refrigerant.
Slow flashing green light, not engaging in defrost mode or in cold weather.		Unit is more likely functioning correctly. If the ambient temperature is too low, the compressor clutch is not allowed to engage, because of low system pressure.	
Slow flashing green light, clutch is engaged, A/C not cooling.		Inoperative blower motor.  Loose or broken compressor belts.	Check for proper operation of the blower motors.  Tighten or replace compressor belts.
Slow flashing green light or poor A/C performance.		A/C drive belt is broken, loose or glazed.  Heater valve left open, valve is broken or cable is not operating properly.  Moisture in the system.  Air ducts leaking air flow.  Loss of charge before detected.	Tighten or replace drive belt.  Turn valve off or replace valve or cable.  Check moisture indicator on drier. Replace if necessary.  Repair air leak problem.  Check with gauge set, repair leak if necessary.

### TO CLEAR FAULT CODES

Clear the error code by cycling ignition switch four times (one second on/one second off) and the green light will reappear.

# Wiring Diagram

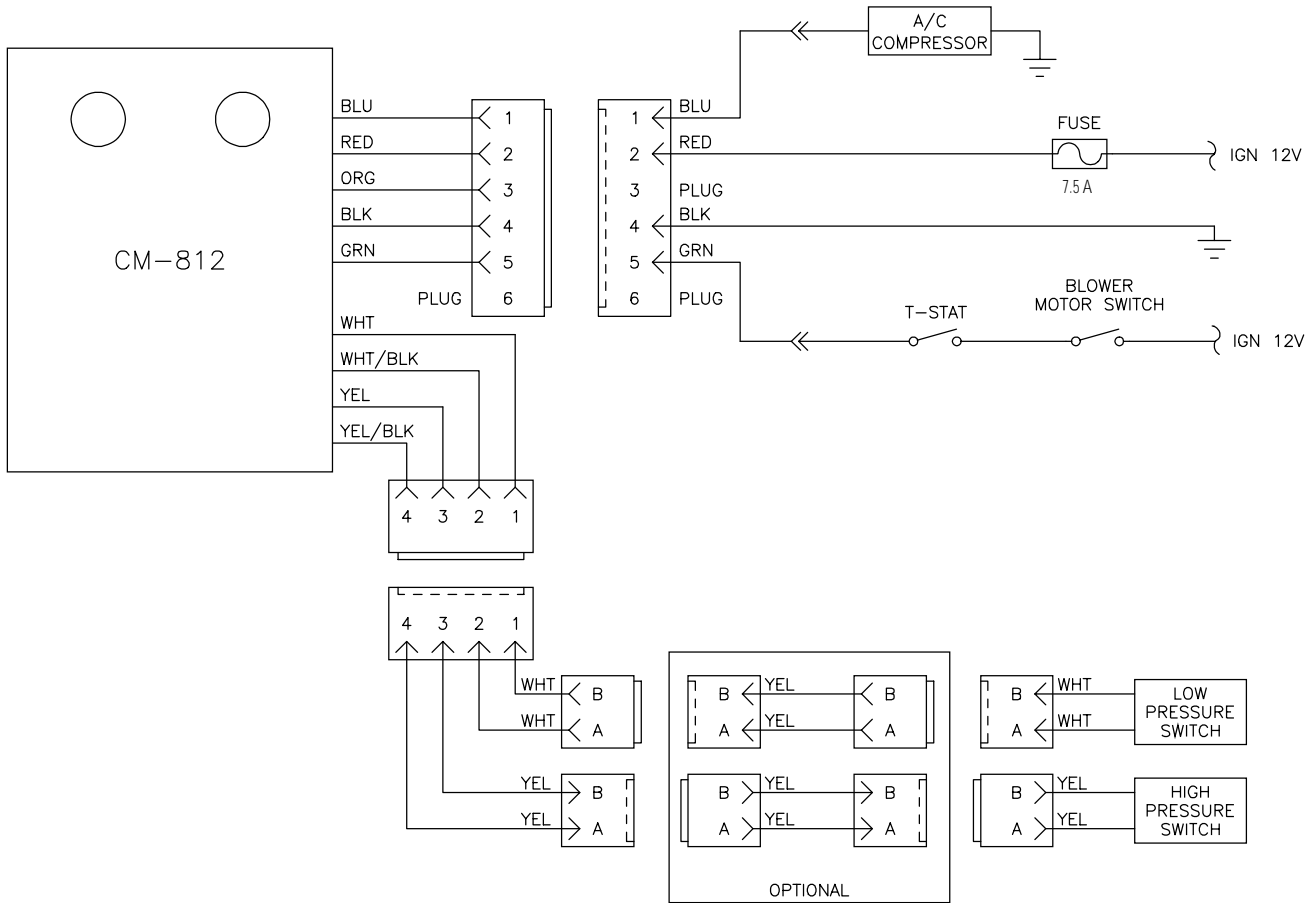

GR00064

# Spare Parts

---

<b>Components</b>		<b>8041121 R134a Without Adapter</b>	<b>8041122 R134a With Adapter</b>	<b>8041123 R134a 1/4 High Port With Adapter</b>	<b>8041124 R12</b>	<b>8041125 R12 Trinary Switch</b>
1	Control module	8042114	8042114	8042114	8042114	8042114
2	High side switch	8040172	8040172	8040171	8040171	8040171
3	Low side switch	8040170	8040170	8040170	8040169	8040169
4	Module harness	8038062	8038062	8038062	8038062	8038062
5	Switch harness	8038063	8038063	8038063	8038063	8038063
6	Fan pressure switch (NO)					8040174
7	Fan pressure switch (NC)					8040175
8	Conduit	4043001	4043001	4043001	4043001	4043001
9	Adapter 1"-14		4042008	4042008		
10	Adapter 7/8"		4042006	4042006		
11	Extension harness	8038061	8038061	8038061	8038061	8038061

# Limited Product Warranty

---

INDEX warrants all of its products to be free from defects in material and workmanship under normal use and service. Any part which proves to be defective in material or workmanship within the Warranty period covering the specific product to which the Warranty applies as specified below, will be repaired or replaced, at Index's option, with a new or functionally operative part.

## General Conditions

INDEX's liability under this Limited Warranty shall be limited to repairing or replacing at its own factory or through an authorized service distributor or dealer, material which is determined by INDEX to have been defective in manufacture and upon which a claim has been made by the original purchaser or user to Index (or an authorized distributor or dealer) within the Warranty period. Claims under this Limited Warranty will be honored only if the product is returned within 90 days of the date that the part was determined to be defective. INDEX specifically assumes no responsibility for labor charges unless prior authorization has been granted before the labor has been performed. Approved return of parts or products will be on a prepaid transportation charge basis only and non-defective products will be returned collect. Claims under this Limited Warranty will be honored only upon return of product and INDEX's determination that the claim is covered by this Limited Warranty, and Index shall incur no obligation under this Limited Warranty prior to such determination. This Limited Warranty does not apply to any device or component which has been: (i) altered or repaired, except by INDEX or its authorized representatives; (ii) subject to misuses, negligence, or accident, including, without limitation, use and operation of such machinery or equipment while any parts are loose, broken, out of order, or damaged by the elements, or; (iii) used for a purpose for which it was not designed or used in conjunction with other products not approved for use by INDEX, or (iv) rendered inoperative due to miswiring or due to broken wires, or related connectors. Parts replaced under this Limited Warranty are warranted only through the remainder of the original Limited Warranty. Any and all claims for Warranty service must include such information as Index designates, and shall include specifically the part number and date code of each unit (if appropriate).

THIS LIMITED WARRANTY IS IN LIEU OF ALL OTHER WARRANTIES, EXPRESS, OR IMPLIED OR STATUTORY, INCLUDING, BUT NOT LIMITED TO, ANY WARRANTY OF MERCHANTABILITY OR FITNESS OF PURPOSE AND ALL OTHER OBLIGATIONS OR LIABILITIES OF INDEX, INCLUDING ANY TORT LIABILITY FOR NEGLIGENT DESIGN OR MANUFACTURE OF THE PRODUCT, OR OTHERWISE.

THIS WARRANTY DOES NOT COVER CONSEQUENTIAL DAMAGES. IN NO EVENT WILL INDEX BE LIABLE TO BUYER FOR LOSS OF PROFITS, LOSS OF USE, OR DAMAGES OF ANY KIND BASED UPON A CLAIM FOR BREACH OF WARRANTY. INDEX EXPRESSLY DENIES ANY WARRANTY, EXPRESSED OR IMPLIED OF FITNESS FOR PURPOSE OR OF MERCHANTABILITY WHERE THE SPECIFIED DESIGN OF THE PRODUCT IS ESTABLISHED BY THE PURCHASER OR INDEX DOES NOT HAVE INTIMATE KNOWLEDGE OF THE INTENDED PURPOSE AND APPLICATION.

INDEX SHALL NOT BE LIABLE UNDER ANY CIRCUMSTANCES FOR ANY INCIDENTAL OR CONSEQUENTIAL DAMAGES, AS THOSE TERMS ARE DEFINED IN THE UNIFORM COMMERCIAL CODE. THE FOREGOING SHALL CONSTITUTE THE SOLE AND EXCLUSIVE LIABILITY OF INDEX IN CONNECTION WITH ITS PRODUCTS.

## APAds Aftermarket Warranty Period

Unless otherwise documented, INDEX's APAds Aftermarket kit is warranted for a period of twelve months, unlimited miles, from the date of sale by *INDEX to Buyer* or date of resale by *Buyer to Buyer's customer*, whichever is the first to expire. If date of installation or resale cannot be documented, the date of installation will be assumed to be ninety days after the manufacturing date coded on the product.

APAds® is a registered trademark of Index Sensors & Controls, Inc. Patent number 5,761,918.  
Trinary™ and Binary™ are registered trademarks of Red Dot Corporation.